



杰斯锐尔电池规格书

JREPower Battery Specifications

产品名称 (Product Name)

12V 70Ah 钠离子电池 (12V 70Ah SODIUM-ION BATTERY)

产品型号 (Product Model)

JSZSNA1555C

地址: 中国广东省深圳市坪山新区龙田社区莹展工业区B4B栋

Address: B4b building Yingzhan Industrial Park, Kengzi town, Pingshan district, Shenzhen city, Guangdong, China

邮编: 518118

ZIP CODE: 518118



目录 Content

1. 产品型号 Model.....	3
2. 外观与尺寸 Appearance And Size.....	3
3. 产品应用 Product Application.....	3
4. 规格 Specification.....	4
5. 标准测试条件 Standard Testing Conditions And Requirements.....	5
6. 外观 Outside Appearance.....	5
7. 包装、储存及运输 Packing/Storage/Shipment.....	5
8. 安全警告及注意事项 Safety Precaution And Prohibitions.....	6
9. 贮存 Storage.....	8
10. 保质期 Guarantee Period Of Quality.....	8

前言 introduction

本产品规格书描述了深圳市杰斯锐尔科技有限公司（JREPower）所生产的钠离子电池主要性能指标，用户请务必按照本规格书中的应用&测试方法进行使用，如果有不明之处，请与供方协商解决。

This product specification describes the main performance indicators of Sodium-ion batteries produced by Shenzhen JREPower Tech Co., Ltd.(JREPower) Users must use them according to the application and test methods in this specification. If there are any unclear points, please negotiate with the supplier to resolve them.

1. 产品型号 Product model

JSZSNA1555C

2. 外观与尺寸 Appearance and size

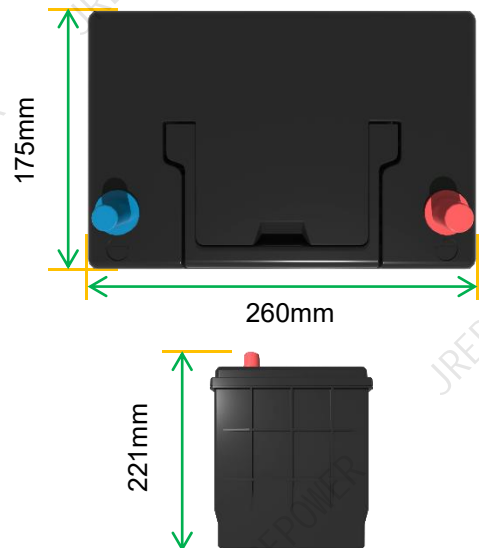

3. 产品应用 Product application

JSZSNA1555C 12V 70Ah 钠离子电池是JREPower所生产的标准版电池之一，主要用于汽车/卡车/船舶，如需用在其他领域，请与供方了解适用性。

JSZSNA1555C 12V 70Ah sodium-ion battery is one of the standard batteries produced by JREPower. It is mainly used in cars/trucks/marine boats. If it needs to be used in other fields, please contact the supplier for applicability.

4. 规格 Specification

	型号 Model	JSZSNA1555C
技术规格 Technical Specifications	电芯材料 Cell Chemistry	钠离子圆柱形电芯 Sodium-ion cylindrical cell
	电芯配置 Cell Configuration	4S7P
	额定容量(Ah) Nominal Capacity(Ah)	70Ah @0.5C放电率 70Ah @0.5C discharge rate
	额定电压(V) Nominal Voltage(V)	12.4V
	额定能量(Wh) Nominal Energy(Wh)	868Wh
	电压范围(V) Voltage Range(V)	6-15.8V
	循环寿命 Cycle Life	3000 次循环 DOD80% 0.2C/0.5C 3000 cycles DOD80% 0.2C/0.5C
	充电 Charging	标准充电电流(A) Standard Charge Current(A)
最大充电电流(A) Max. Charge Current(A)		70A
充电环境 Charge Condition		@0°C~60°C
放电 Discharging	标准放电电流(A) Standard Discharge Current(A)	0.5C (恒流放电) 0.5C(Constant current discharging)
	最大持续放电电流(A) Max. Continuous Discharge Current(A)	140A
	冷启动能力 CCA	1400
	放电环境 Discharge Condition	@-30~65°C
保护及功能 Protection & Function	通讯功能 Balance Function	是 Yes
	通讯 Communication	-
	加热系统(可选) Heating System(optional)	可根据需要提供 Available upon requirements
外形和尺寸 Appearance And Size	尺寸 Size	260*175*221 mm 10.2*6.9*8.7 in
	重量 Weight	8.0±0.5 kg 18.7±1.1 lbs
	外壳 Enclosure	塑料外壳, IP67 ABS Case, IP67
	端子/接口 Terminals/Interfaces	M8
维护与存储 Maintenance & Storage	维护 Maintenance	电池组应每3个月完全充电一次。 The battery pack should be fully charged every 3 months.
	储存条件: -20~25°C Storage Condition @-20~25°C	能以50%的容量保留3个月 Can be kept for 3 months at 50% capacity
	储存条件: @-20~45°C Storage Condition @-20~45°C	能以50%的容量保留1个月 Can be kept for 1 month at 50% capacity

5. 电池标准测试条件 Standard Testing Conditions and Requirements

5.1 标准测试条件和要求 Standard Testing Conditions And Requirements

测试的电池是出厂时间不超过 3 个月的新电池，在 0-35°C 以及 30-50% 带电量下储存，且电池未进行过五次以上充放电循环。除非其它特殊要求，本产品规格书规定的测试条件为：温度 $25 \pm 2^\circ\text{C}$ 。

The tested battery is a new battery that has been manufactured for no more than 3 months, stored at 0-35°C and 30-50% charge, and the battery has not been charged and discharged for more than five times. Unless otherwise specified, the test conditions specified in this product specification are: temperature $25 \pm 2^\circ\text{C}$.

5.2 测量设备及仪表 Measurement Equipment And Instrumentation

5.2.1 尺寸测量 Measurement Tool

用精度为 0.1mm 的卡尺或更高精度的工具测量尺寸，量程范围 0~ 1000mm。

Measure the size with a caliper with an accuracy of 0.1mm or a tool with higher accuracy, with a measuring range of 0~1000mm.

5.2.2 电压测量 Measurement Voltage

用精度为 0.01V 的电压表测量电压，量程范围 0~100V。

Use a voltmeter with an accuracy of 0.01V to measure the voltage, with a range of 0~100V.

5.2.3 电流测量 Measurement Current

用精度为当前电流 $\pm 1\%$ 的电流表测量电流，量程范围 0~ 400A。

Use an ammeter with an accuracy of $\pm 1\%$ of the current to measure the current, with a range of 0~400A.

5.2.4 内阻测量 Measurement Impedance

用一个 0 - 10mΩ 的电阻仪测量内阻。

Measure the internal resistance using a 0 - 10mΩ ohmmeter.

6. 外观 Outside Appearance

不允许有任何影响电池性能的外观缺陷，如电芯漏液、电池生锈、电池变形、元器件破损、严重炸火等。

Any appearance defects that may affect battery performance are not allowed, such as battery leakage, battery rust, battery deformation, component damage, serious fire, etc.

7. 包装、储存及运输 Packing/Storage/Shipment

7.1 电池装运前的检查 Pre shipment inspection

对于所有电池，在装运前需检查其电压、内阻与保护电路的功能。

All batteries must be checked for voltage, internal resistance and functionality of protection circuits before shipment.



7.2 包装与运输电池 Packing and Shipping

7.2.1 当电池需要再运输以便在工厂装配时，要特别注意包装，以避免运输时产生应力。JREPower公司建议再运输时，使用JREPower公司运输时同样的包装。即使打开了包装，当再运输时，使用JREPower公司同样的部件和材料进行再包装。

7.2.1 When batteries need to be retransported for assembly in the factory, pay attention to packaging to avoid stress during transportation. JREPower recommends that the same packaging used in JREPower shipping be used when reshipping. Even if the packaging is opened, when reshipped, the same parts and materials from JREPower are used for repackaging.

7.2.2 电池应在不低于50%的电量状态下，包装成箱进行运输。在运输过程中，防止剧烈振动、冲击、挤压，防止日晒雨淋，应使用汽车、火车、轮船、飞机等交通工具运输。

Batteries should be packed into boxes for transportation when the battery power is not less than 50%. During transportation, avoid severe vibration, impact, extrusion, sun and rain, and use vehicles, trains, ships, airplanes and other means of transportation.

7.3 电池异常 Abnormal Condition

当电池由于运输中的应力、跌落、短路或其它原因被损害并发出电解液异味时，请勿使用。

Do not use the battery if it is damaged due to stress during transportation, falling, short circuit or other reasons and emits an electrolyte odor.

8. 安全警告及注意事项 Safety Precaution And Prohibitions

为了防止电芯出现泄漏、发热、着火、性能降低或寿命下降、爆炸等事故，请按如下操作规定正常使用电池，并遵守防范事项。

In order to prevent accidents such as leakage, heating, fire, performance reduction or life reduction of the battery, explosion, etc., please use the battery normally according to the following operation rules and follow the precautions.

8.1 充电 Charging

8.1.1 充电电流 Charging Current

充电电流不得超过规格中最大充电电流。使用高于推荐值电流充电将可能引起电池的充放电性能、机械性能和安全性能的问题，并可能会导致发热或泄漏。

The charging current shall not exceed the maximum charging current specified in the specification. Charging with a current higher than the recommended value may cause problems with the charge-discharge performance, mechanical properties, safety of the battery, and may cause heating or leakage.

8.1.2 充电电压 Charging Voltage

充电电压不得超过电压范围的最大值。充电器的设计应满足此条件。电池电压高于电压范围的最大值时，将可能引起电池的充放电性能、机械性能和安全性能的问题，可能会导致发热、泄漏或爆炸。

The charging voltage must not exceed the maximum value of the voltage range. The charger design should meet this condition. When the battery voltage is higher than the maximum value of the voltage range, it may cause problems with the battery's charging and discharging performance, mechanical properties and safety performance, and may cause heating, leakage or explosion.

8.1.3 充电温度 Charging Temperature

电池必须在 0°C~60°C 的环境温度范围内进行充电。

The battery must be charged in an ambient temperature range of 0°C~60°C.

8.1.4 禁止反向充电 Reverse Charging Is Prohibited

正确连接电池的正负极，严禁反向充电。若电池正负极接反，将无法对电池进行充电。同时，反向充电会降低电池的充放电性能、安全性，并会导致发热、泄漏或爆炸。

Connect the positive and negative poles of the battery correctly, and reverse charging is strictly prohibited. If the positive and negative poles of the battery are connected in reverse, the battery cannot be charged. At the same time, reverse charging will reduce the battery's charging and discharging performance and safety, and may cause heating, leakage or explosion.

8.2 放电 Discharging

8.2.1 放电电流 Discharging Current

放电电流不得超过本规格中最大放电电流，大电流放电会导致电池容量剧减并导致过热。

The discharge current must not exceed the maximum discharge current in this specification. Large current discharge will cause a sharp drop in battery capacity and lead to overheating.

8.2.2 放电温度 Discharging Temperature

电池必须在 -10°C~60°C 的环境温度范围内进行放电。

The battery must be discharged within the ambient temperature range of -10°C~60°C.

需要注意的是，在电池长期未使用期间，它可能会用其它自放电特性而处于某种过放电状态。为防止过放电的发生，电池应定期充电，将其电压维持在工作电压范围之内。过放电会导致电池性能、电池功能的丧失。

It should be noted that when the battery is not used for a long time, it may be in a state of over-discharge due to other self-discharge characteristics. To prevent over-discharge, the battery should be charged regularly to maintain its voltage within the operating voltage range. Over-discharge will lead to loss of battery performance and battery function.

8.3 异常处理 Exception Handling

如果电池出现被破坏、变形、电芯电解液泄漏或闻到有电解液味道以及其他不正常现象，请不要再使用该电池；此外，泄漏电解液的电池应远离火源，并对，避免引起爆炸。

If the battery is damaged, deformed, leaking electrolyte, or smells of electrolyte, or other abnormal phenomena occur, please do not use the battery again; in addition, batteries with leaking electrolyte should be kept away from fire sources, and the batteries should be punctured and immersed in water to avoid explosion.

9. 贮存 Storage

9.1 贮存温度与湿度 Storage Temperature And Humidity

电池应贮存在环境温度范围为0°C~35°C，相对湿度在0%~75%的清洁、干燥、通风的室内，应避免与腐蚀性物质接触，应远离火源及热源。

The battery should be stored in a clean, dry, and ventilated room with an ambient temperature range of 0°C~35°C and a relative humidity of 0%~75%. Avoid contact with corrosive substances and keep away from fire and heat sources.

9.2 长时间储存 Long Time Storage

如果要长时间贮存，电池应在温度范围0°C~35°C、相对湿度在0%~75%和无腐蚀性气体环境中贮存。超过三个月时，应对电池进行一次完全充放电循环，再将电池充电至50%条件下贮存。

If the battery is to be stored for a long time, it should be stored in a temperature range of 0°C~35°C, relative humidity of 0%~75% and in a non-corrosive gas environment. If it exceeds three months, the battery should be fully charged and discharged once, and then stored under the condition that the battery is charged to 50%.

10. 保质期限 Guarantee Period of Quality

电池在出厂后，若因为制造生产或工艺因素，且非人为损坏（如异常使用/过失损坏/私自拆解等）或不可抗力因素（如自然灾害/社会异常事件等）导致的产品质量问题，JREPower可在1年内免费更换新电池，3年内对电池负责保修服务。

After the battery leaves the factory, if there are any quality problems with the product due to manufacturing or process factors, and non-human damage (such as abnormal use/negligent damage/unauthorized disassembly, etc.) or force majeure factors (such as natural disasters/abnormal social events, etc.), JREPower can replace the battery with a new one free of charge within 1 year and provide warranty service for the battery within 3 years.